

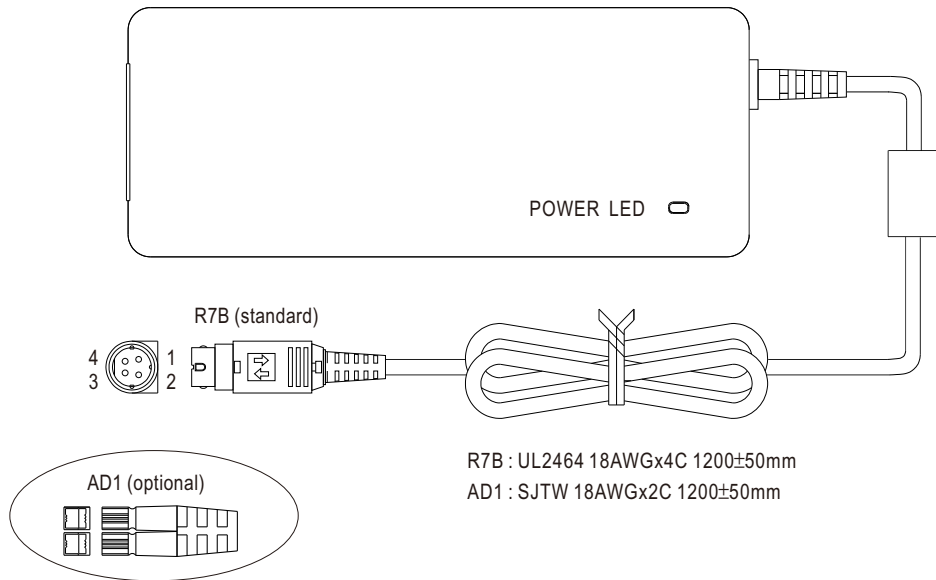

GC120 Instruction Manual

GC120 Instruction Manual



DC output connector (standard)

R7B (KYCON KPP-4S or equivalent)		PIN NO.	OUTPUT
4	1	1,4	+V
3	2	2,3	-V

AC FG

-V connected to AC FG

DC output connector (optional)

AD1 [housing: Anderson 1327FP(red), 1327G6FP(black) contacts: Anderson 261G2 (45A) or equivalent]	
Red(+V)	Black(-V)



WARNING : Please make sure the polarity of the battery is connected correctly!

Assembly Procedure:

1. Make sure the charger is shut off and choosing suitable wires to connect the charger and batteries based on the rating of charging current. The polarity must be correct: charger output (+) should be connected to the (+) terminal of batteries and charger output (-) should be connected to the (-) terminal.
In no times should the (+) and (-) be short together or the charger and batteries will be damaged.
2. Connect the AC input and check whether the operation of LED is correct.
(red : charging ; green : battery is full)

Notes On Operation:

1. The charger should be assembled in the place with good ventilation and low moisture.
Exposure to the rain or snow is strictly prohibited.
2. Wires connecting between the charger and batteries should be as short as possible since the high voltage drop on the wires will increase the time required to fully charge the batteries.
3. The charger is suitable for lead-acid batteries (flooded, Gel and AGM) and Li-ion batteries (lithium iron and lithium manganese).
Make sure the charging voltage and charging current are suitable for the batteries you are using. Modification for charger specification may be required for different battery specification. Please contact battery vendor and MEAN WELL for details.
4. If the batteries need to connect in series for charging, old batteries are not suggested to be used with new ones or the lifetime of batteries may reduce because of the unbalance charging voltage distribution on new and old batteries.
5. Please turn off the charger before connecting or disconnecting the wires.
6. The charger has a 2-year worldwide warranty, however, damages from misusing the charger will not be included in the coverage of warranty.

Status Under General Operation:

At the beginning stage of operation, the charger provides the largest current with 13.6Vdc of output voltage (for 12V batteries) to charge batteries. The LED indicator will lighten in red. After a period of time (probably a couple of hours, based on the capacity of batteries), the charging current will decrease gradually. After reaching 10% of its maximum value, the charger will go into "floating-charge" stage. The LED indicator will turn to green. The relationship between charging current and charging voltage for each operation stage are shown in the curves below :

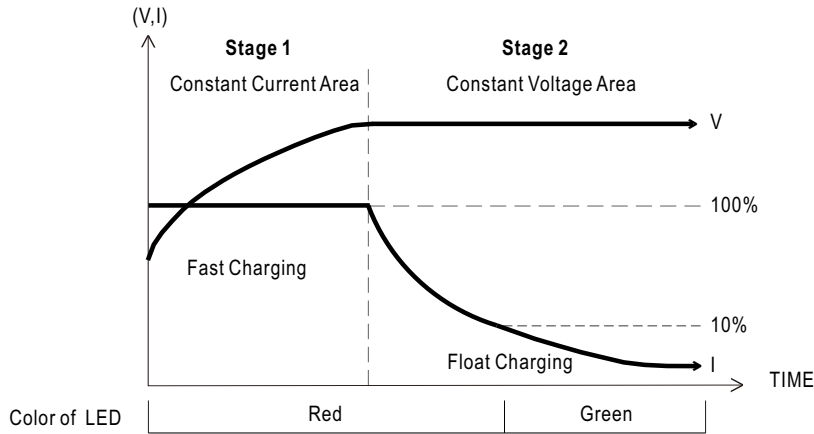

Charging Current And Ambient Temperature

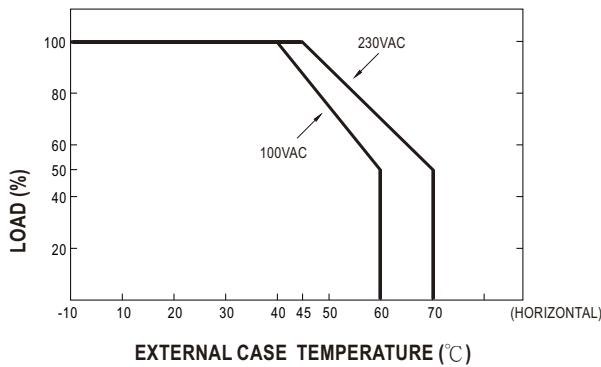

Suggested Battery Capacity:

- 1.It will not have any problem if the capacity of batteries larger than the suggested value. It just takes more time to make the batteries fully charged!
- 2.If you have any question about the suitable charging current for the batteries, please refer to the technical data provided by the battery manufacturers or consult the vendor of the batteries.

Model	Suggested Battery capacity
GC120A12	40-100Ah
GC120A24	20-65Ah
GC120A48	10-35Ah

Suitable for lead-acid batteries (flooded, Gel and AGM) and li-ion batteries (lithium iron and lithium manganese)

Notes On Failure Elimination

Status	Possible Reasons	Ways to Eliminate
No output voltage	Wrong polarity of the battery connection	Repair required. Please send it back to us or any of our distributors
Can't achieve the FLOAT (green light) stage after long period of charging operation	Batteries are aging or broken	Replace the batteries

If you still cannot eliminate the failure situation, please consult MEAN WELL or any of our distributors

IMPORTANT SAFETY INSTRUCTIONS - SAVE THESE INSTRUCTIONS

DANGER - TO REDUCE THE RISK OF FIRE OR ELECTRIC SHOCK.

CAREFULLY FOLLOW THESE INSTRUCTIONS.

- 1.This manual contains important safety and operating instructions for battery charger Models GC120A12,GC120A24 and GC120A48.
- 2.SAVE THESE INSTRUCTIONS -This manual contains important safety and operating Instructions for battery charger Models GC120A12, GC120A24 and GC120A48.
- 3.Before using battery charger, read all instructions and cautionary markings on battery charger, battery, and product using battery.

4. CAUTION - To reduce risk of injury, charge only one, 12V Lead-Acid type rechargeable battery for Model GC120A12; charge only two, 12V Lead-Acid type rechargeable batteries, which were connected in series, for Model GC120A24; charge only four, 12V Lead-Acid type rechargeable batteries, which were connected in series, for Model GC120A48.

5.Power Supply Cord:

Power Supply Cord - Cord Type SJT or SVT, rated minimum 105°C, No. 18AWG/3C,provided with a molded-on, grounding type attachment plug with a 15A, 125V(NEMA 5-15p) configuration and a molded-on connector which mates with the appliance inlet, minimum 1.8m and maximum 3m in length.

- 6.The equipment was investigated under 20 amperes branch circuit in accordance with the National Electrical Code, ANSI/NFPA 70, to reduce the risk of fire, connect only a circuit provided with 20 amperes maximum branch over current protection.